



**MCE1012E SERIES LOW PROFILE TYPE  
(Chip Common Mode Filter plus ESD function) Engineering Specification**

**Features and Application**

- Powerful components with composite co-fired material to solve EMI problem for high speed differential signal transmission line as USB, and LVDS, without distortion to high speed signal transmission.
- Common mode filter plus ESD function.
- MIPI, MHL serial interface in mobile device.

**1.PRODUCT DETAIL**

Part No.	Imp. Com. (Ω)±25% @100MHz	DCR Max. (Ω)	Rated Current Max.(mA)	Working Voltage (V)	Insulation Resistance Min.(MΩ)	Capacitance (pF) @0.5V 1MHz Max(pF)	Leakage Current @5V Max(μA)	Trigger Voltage Typ. (V)	Clamping Voltage Typ. (V)
MCE1012E 360F06BP	36	0.5	300	10	200	0.7	1	400	50
MCE1012E 900F06BP	90	0.6	300	10	200	0.7	1	400	50
•Meet IEC61000-4-2 level 4: Contact Discharge 8KV · Air Discharge 15KV									
Test Instru ments	•Agilent E4991A RF IMPEDANCE / MATERIAL ANALYZER •HP4338B MILLIONMMETER •Agilent E5071C S-PARAMETER NETWORK ANALYZER •HP4285A PRECISION LCR METER •Agilent 4339B HIGH RESISTANCE METER •Keithley 2410 1100V SOURCE METER •Celestron TLP								

**2.PART NUMBER CODE**

MCE 1012 E 90 0 F 06 B P  
1 2 3 4 5 6 7 8 9

- 1 : Series name
- 2 : Dimensions L\*W
- 3 : Material code
- 4 : Impedance value (ex : 900=90Ω)
- 5 : Fixed decimal point
- 6 : Rated Current Code

A=50mA	B=80mA	C=100mA	D=150mA	E=200mA	F=300mA
G=400mA	H=500mA	I=600mA	J=700mA	K=800mA	

- 7 : Dimension T (ex : 06=0.60mm)
- 8 : Soldering: Green Parts: A— Soldering Lead-Free B— Lead-Free for whole chip
- 9 : Packaging: P – Embossed paper tape, 7”reel.

3.TYPICAL CHARACTERISTIC

**MCE1012E360F06BP**

IMPEDANCE vs. FREQUENCY CHARACTERISTICS

INSERTION LOSS vs. FREQUENCY CHARACTERISTICS

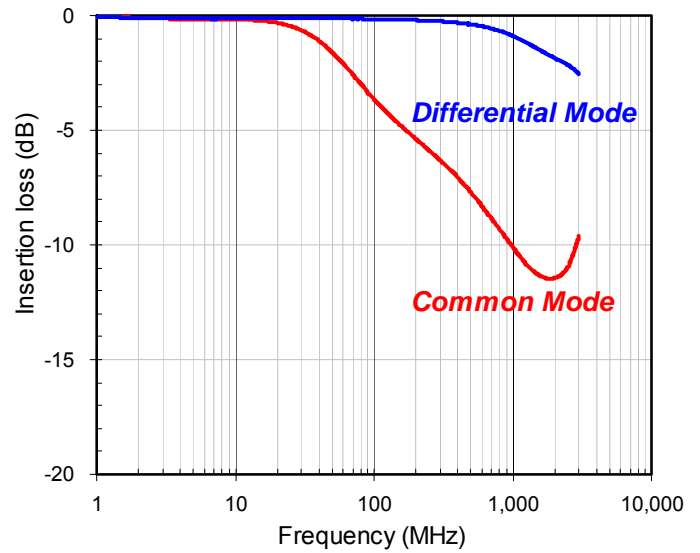
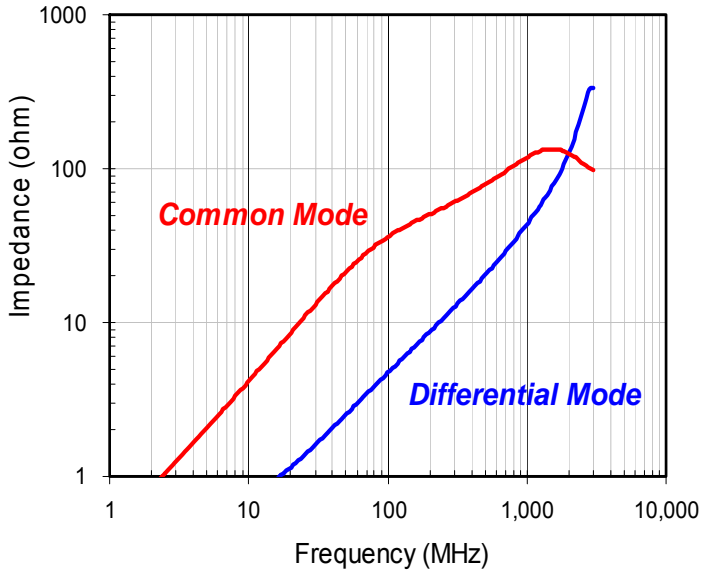

**MCE1012E900F06BP**

IMPEDANCE vs. FREQUENCY CHARACTERISTICS

INSERTION LOSS vs. FREQUENCY CHARACTERISTICS

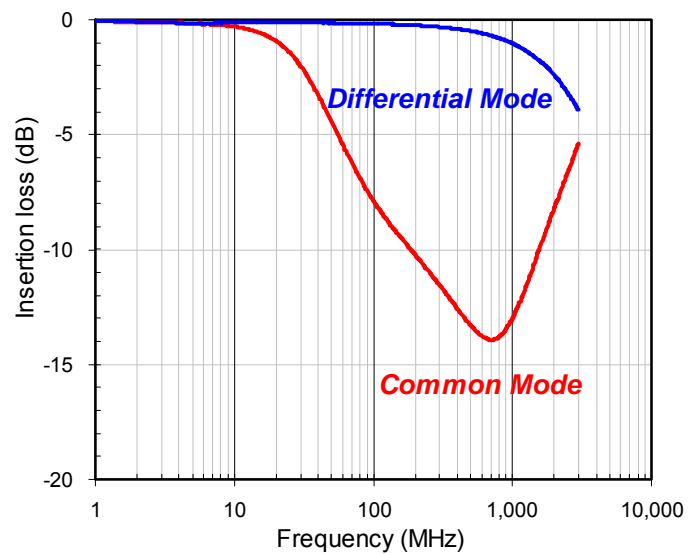
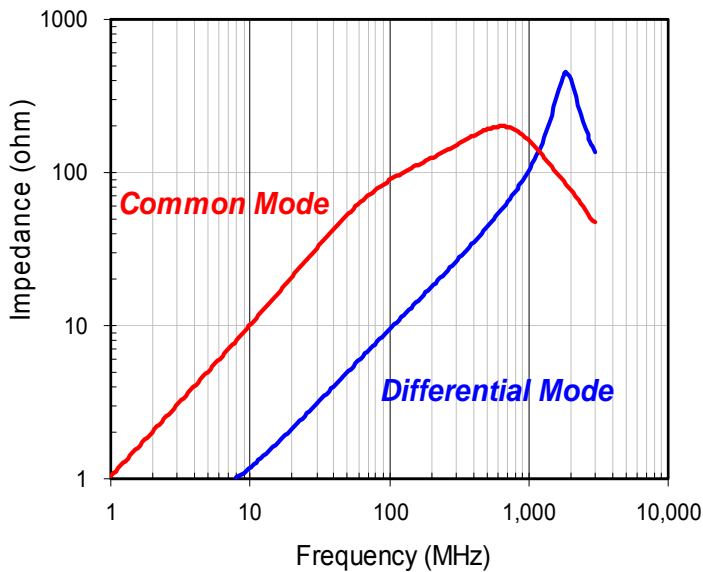

Eye pattern USB 2.0 high speed

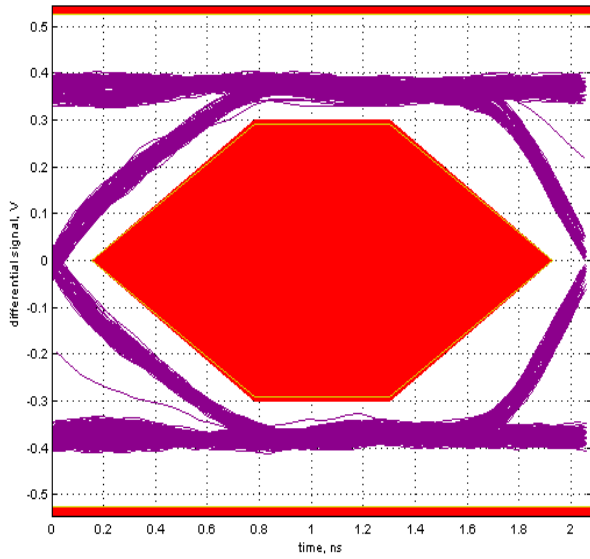

ESD Wave forms

IEC 8KV\_ESD Contact

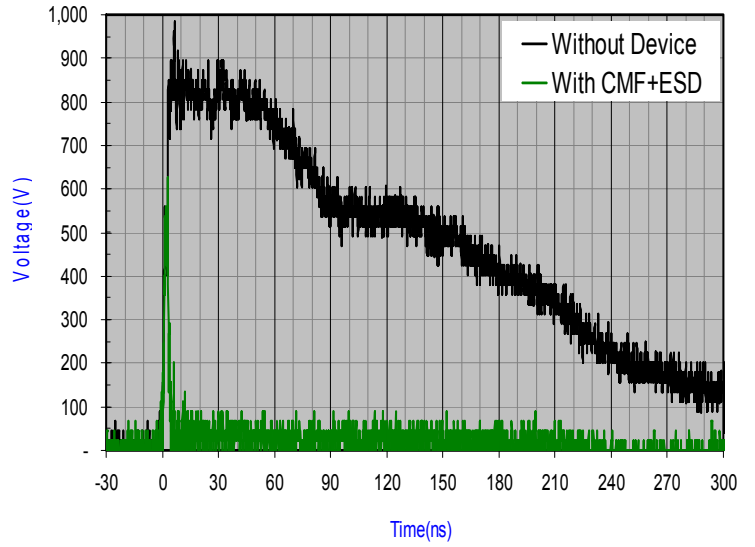

4. SHAPES AND DIMENSIONS

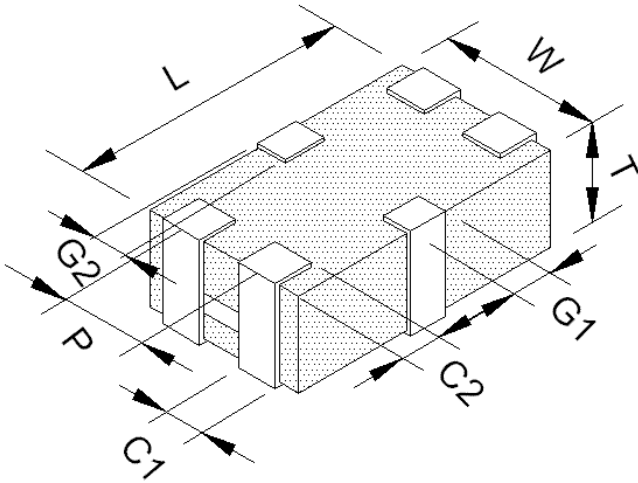

TYPE	Dimension
L	1.25±0.10
W	1.00±0.10
T	0.60±0.10
P	0.50±0.10
C1	0.30±0.10
C2	0.20±0.15
G1	0.30±0.15
G2	0.20±0.15
Unit : mm	

5. CIRCUIT CONFIGURATION & LAYOUT PAD

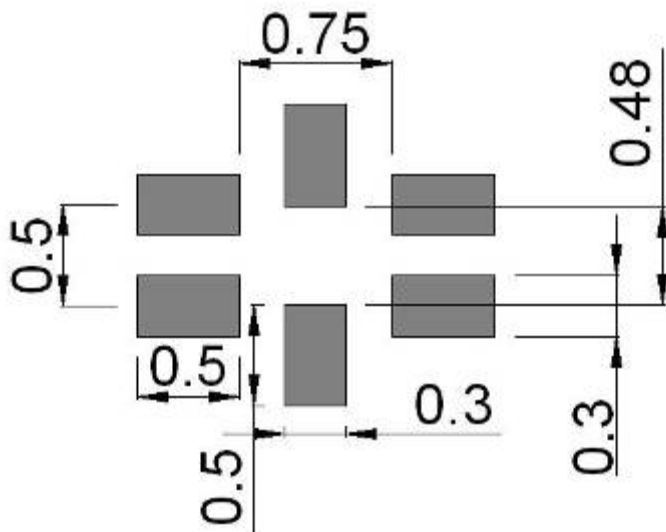
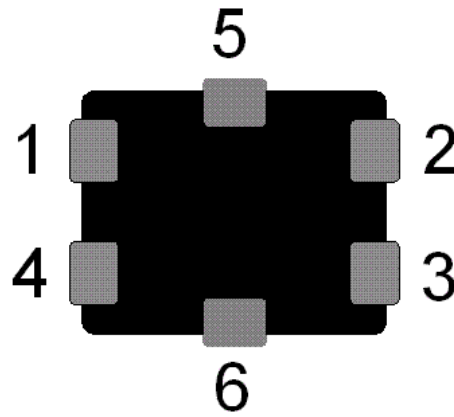
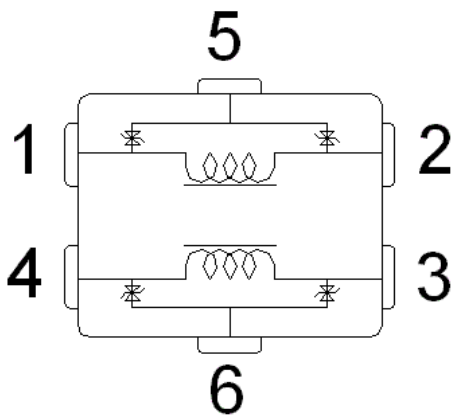

6.TAPE AND REEL SPECIFICATIONS/ TAPING DIMENSIONS

Type : Paper Carrier

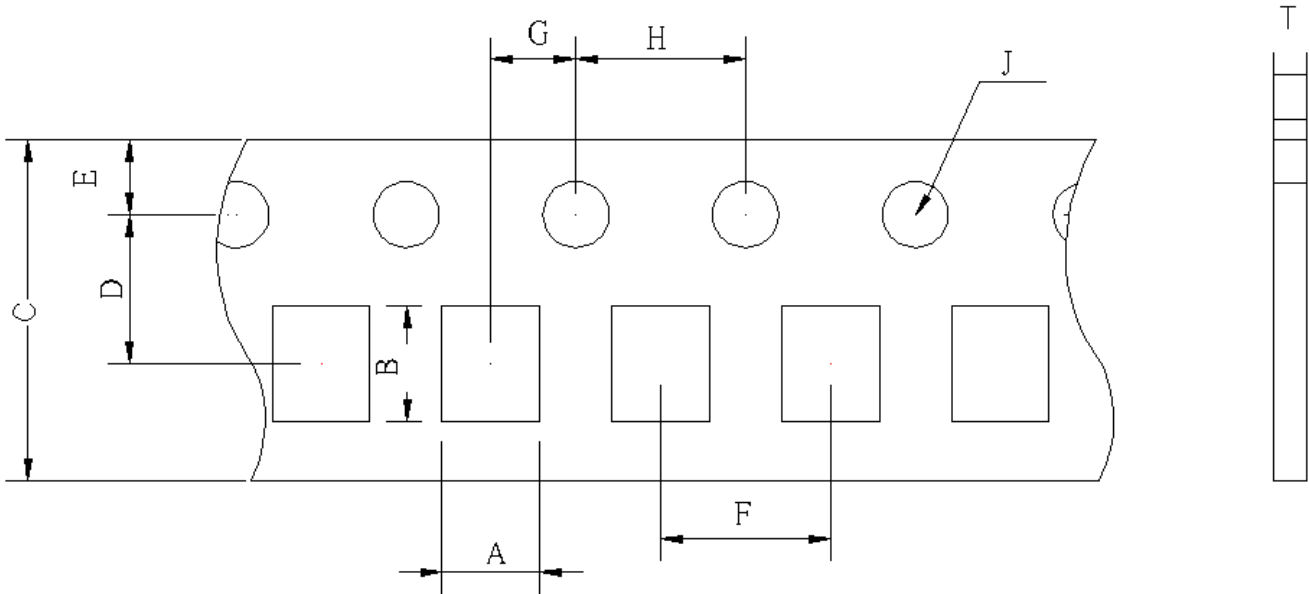

Unit : mm

Symbol	Size	Symbol	Size
C	8.00±0.10	H	4.00±0.10
D	3.50±0.05	J	Φ1.55±0.05
E	1.75±0.05	T	0.75±0.03
F	4.00±0.10	A	1.20±0.05
G	2.00±0.05	B	1.45±0.05

7. REEL DIMENSIONS

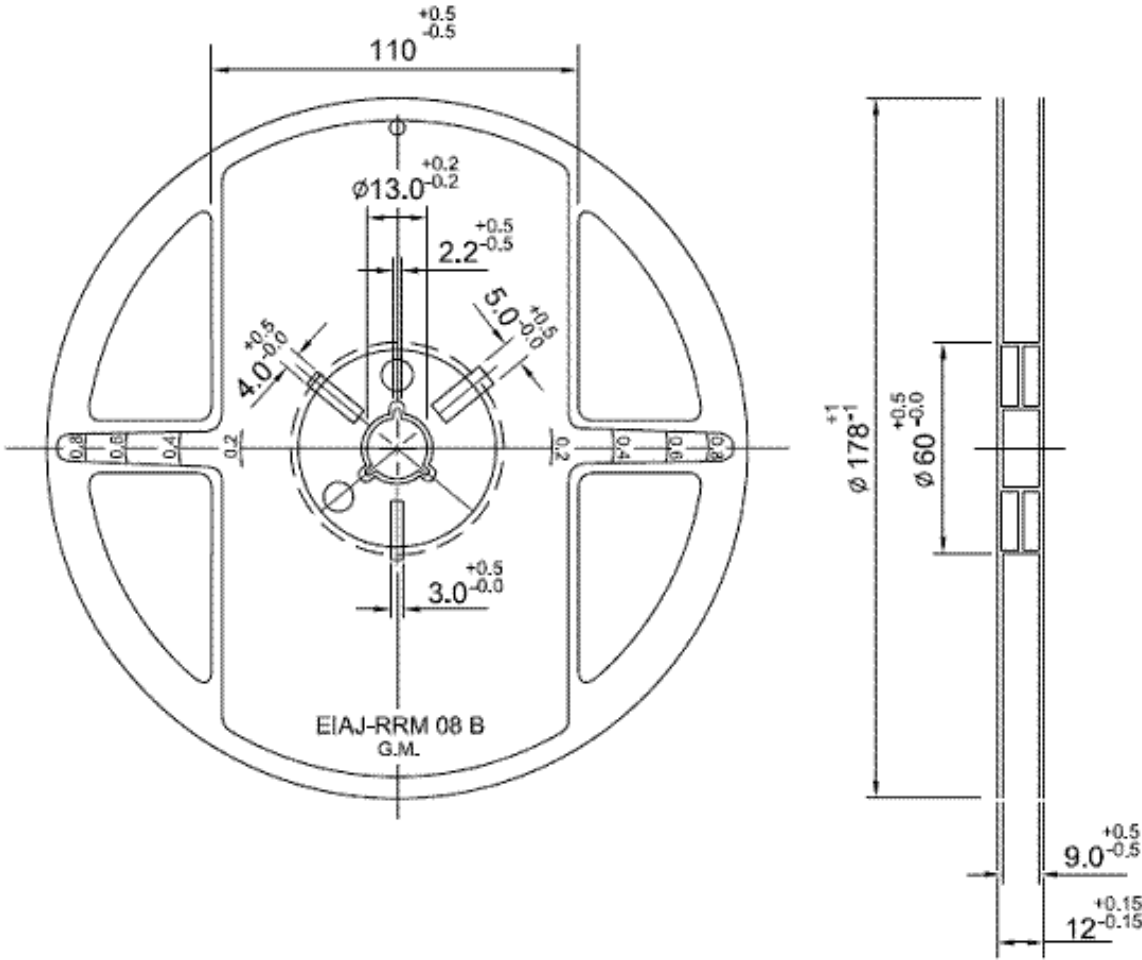

Unit : mm

8. STANDARD QUANTITY FOR PACKAGING

Packaging style : Taping

Reel packaging quantity : 4000 pcs/reel

Inner box : 5 reel/inner box

9.RECOMMENDED SOLDERING CONDITIONS

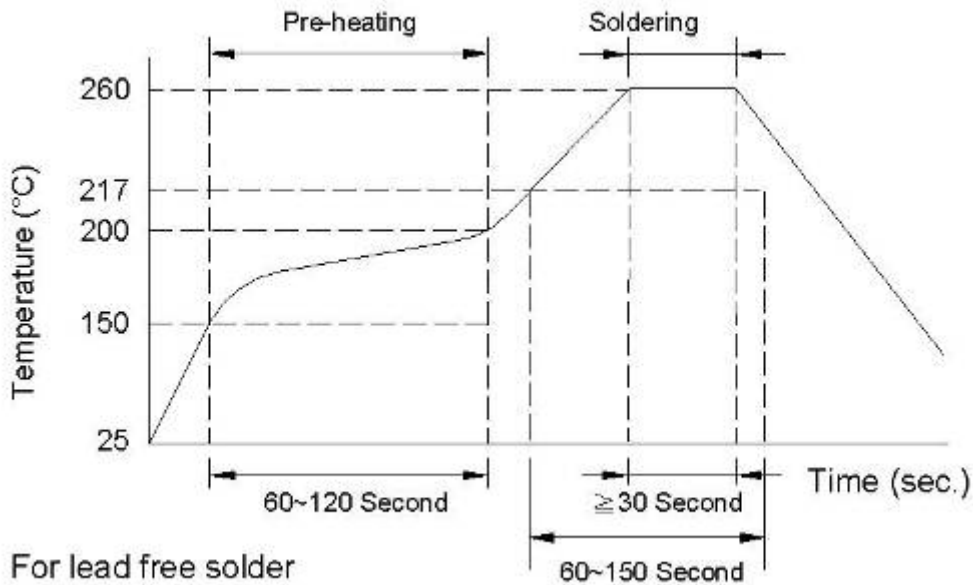

10.GENERAL TECHNICAL DATA

- Operating temperature range : - 40°C ~ +85°C
- Storage Condition : Less than 40°C and 70% RH
- Storage Time: 6 months Max.
- Soldering method: Reflow or Wave Soldering

11.RELIABILITY AND TEST CONDITION

Test item	Test condition	Criteria
<b>Temperature Cycle</b>	A. Temperature : -40 ~ +85°C B. Cycle : 100 cycles C. Dwell time : 30minutes Measurement : at ambient temperature 24 hrs after test completion	A. No mechanical damage B. Impedance value should be within ± 20 % of the initial value
<b>Operational Life</b>	A. Temperature : 85°C ± 5°C B. Test time : 1000 hrs C. Apply current : full rated current Measurement : at ambient temperature 24 hrs after test completion	A. No mechanical damage B. Impedance value should be within ± 20 % of the initial value

<p><b>Biased Humidity</b></p>	<p>A. Temperature : <math>40 \pm 2^{\circ}\text{C}</math>                  B. Humidity : 90 ~ 95 % RH                  C. Test time : 1000 hrs                  D. Apply current : full rated current                  Measurement : at ambient temperature 24 hrs after test completion</p>	<p>A. No mechanical damage                  B. Impedance value should be within <math>\pm 20\%</math> of the initial value</p>
<p><b>Resistance to Solder Heat</b></p>	<p>A. Solder temperature : <math>260 \pm 5^{\circ}\text{C}</math>                  B. Flux : Rosin                  C. DIP time : <math>10 \pm 1</math> sec</p>	<p>A. More than 95 % of terminal electrode should be covered with new solder                  B. No mechanical damage                  C. Impedance value should be within <math>\pm 20\%</math> of the initial value</p>
<p><b>Steam Aging Test</b></p>	<p>A. Temperature : <math>93 \pm 2^{\circ}\text{C}</math>                  B. Test time : 4 hrs                  C. Solder temperature : <math>235 \pm 5^{\circ}\text{C}</math>                  D. Flux : Rosin                  E. DIP time : <math>5 \pm 1</math> sec</p>	<p>More than 95 % of terminal electrode should be covered with new solder</p>
<p><b>ESD test</b> (contact discharge)</p>	<p>A. Voltage : 8kV(level 4)                  B. Polarity : +, -                  C. ESD gun : IEC61000-4-2 standard                  Measurement : at ambient temperature 24 hrs after test completion</p>	<p>A. No mechanical damage                  B. Leakage current : within <math>10\mu\text{A}</math></p>
<p><b>ESD test</b> (air discharge)</p>	<p>A. Voltage : 15kV(level 4)                  B. Polarity : +, -                  C. ESD gun : IEC61000-4-2 standard                  Measurement : at ambient temperature 24 hrs after test completion</p>	<p>A. No mechanical damage                  B. Leakage current : within <math>10\mu\text{A}</math></p>

12.NOTE

All the products in this specification comply with RoHS 1.0 directive.